

Guidance - Supplement to the manual of instructions

Microprocessor Temperature Controller MP-988

Interfaces: Current Loop 20mA, RS-232, RS-485
and CAN-bus



Controller version 909 / E / B

08/2014
Version: 09

TOOL-TEMP

TOOL-TEMP AG
Industriestrasse 30

CH-8583 Sulgen
Schweiz - Suisse - Switzerland

Tel.: +41 (0)71 644 77 77
Fax: +41 (0)71 644 77 00

E-Mail: info@tool-temp.ch
Internet: www.tool-temp.ch

General information

This documentation is copyrighted. Unauthorised duplication is prohibited by law. To the best of our knowledge and belief, the information contained in this documentation is true and correct as of the date of publication. The contents, however, do not constitute a binding obligation on the part of TOOL-TEMP AG and are subject to change without notice.

In case of inconsistencies in the English translation, the German version shall prevail.

© Copyright 2014 TOOL-TEMP AG

NOTE



**This guidance provides specific information to the temperature controller.
Observe the General Safety Information in the manual of instructions to the
TOOL-TEMP machine!**

Contents

1. Overview MP-988	3
1.1. Connection – wiring guidelines.....	5
1.2. Interface adapter SA988 and pin assignment.....	6
2. Overview programs of the controller.....	7
3. Selection of the controller programme	9
4. Settings.....	9
5. Navigation in the controller	9
6. Parameter – Overview	11
6.1. General.....	11
6.2. Inputs.....	12
6.3. Controller	13
6.4. Flow control	14
6.5. Outputs	15
6.6. Limit values.....	16
6.7. Ramp controller	17
6.8. Communication.....	20
7. Communication – Overview Interfaces	21
7.1. Interfaces (P800)	21
7.2. Protocols (P801).....	21
8. Connection diagrams – communication connection	23
8.1. Interface RS-232 – connection diagram	23
8.2. Interface Current Loop 20mA or TTY – connection diagram.....	24
8.3. Interface CL or TTY – Configuration of the connection panel	25
8.4. Interface wire to Krauss Maffei-Injection moulding machine for CL 20mA	26
8.5. Interface RS-485– connection diagram	27
8.6. Interface RS-485 – Configuration of the connection panel.....	28
8.7. Interface CAN-bus – Connection diagram.....	29
8.8. Interface CAN-bus – Configuration of the connection panel	30

1. Overview MP-988

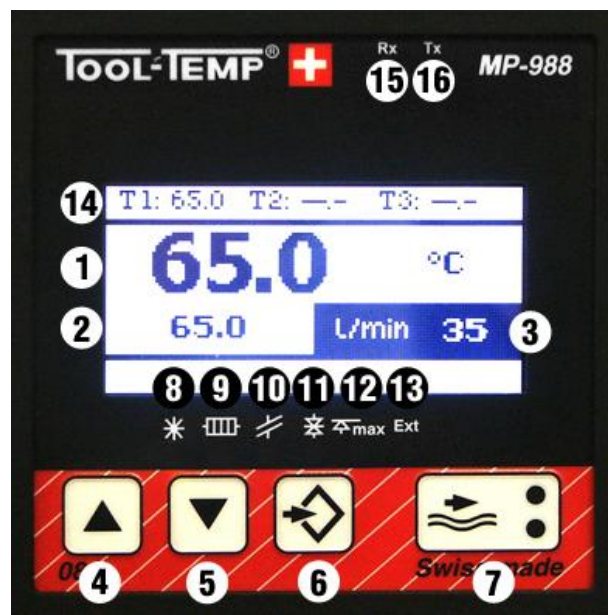

1	Display of set value	2	Display of actual value
3	Flow control Display of the current flow in litres/min, English or American gallons/min.		
4	Up arrow	Raise of set value	
5	Down arrow	Reduction of set value	
6	Program button		
7	Flow control Flow control active Alarm flow control		LED green LED red
8	LED Cooling Lights up when the cooling relay is activated		
9	LED Heating Lights up when the heating relay is activated		
10	LED Sensor failure Lights up when the sensor is intermitted or the wrong type of sensor is used		
11	LED Temperature deviation control Lights up when the difference between set and actual temperature is too high		
12	LED Maximum temperature Lights up when the maximum temperature has been reached		
13	LED External temperature control Lights up when the set value is applied from extern		
14	T1 = Sensor 1 - Actual value T2 = Sensor 2 - Temperature to mould T3 = Sensor 3 - Temperature from mould		(at this value is controlled) (relevant for performance measurement) (relevant for performance measurement)
15	LED Receiving	16	LED Send

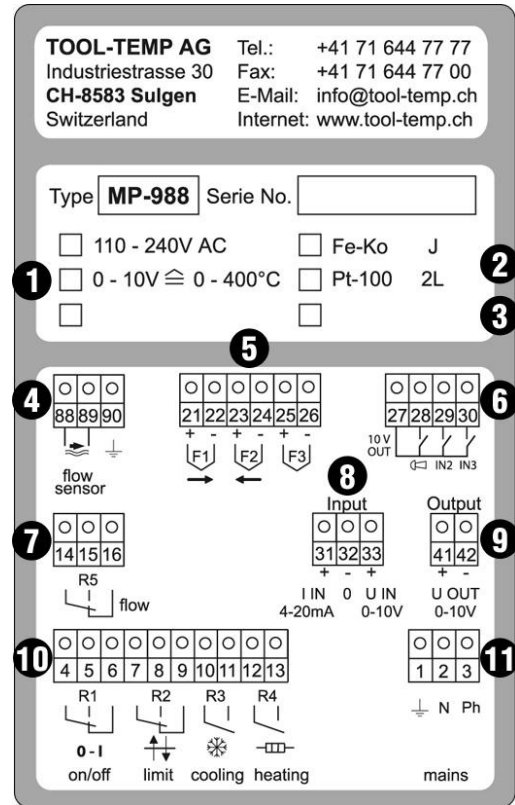

1	Possible supply voltages	(factory adjusted)
2	Possible temperature sensor	(factory adjusted)
3	Version of the controller	
4	88+89 Flow control – encoder signal 90 PE	(factory occupied) (factory occupied)
5	Temperature sensor connection 21+22 Temperature sensor 1 – note + / - 23+24 Temperature sensor 2 – note + / - 25+26 Temperature sensor 3 – note + / -	(factory occupied)
6	27+28 Collective alarm 10V Output	(reserved 29,30)
7	14+15 Output flow control normally open 14+16 Output flow control normally close	
8	31+32 Analog input 4 - 20mA 32+33 Analog input 0 - 10 V	
9	41+42 Analog output 0 - 10V	
10	4+5+6 Input unit ON/OFF 7+8+9 Temperature monitoring, deviation alarm 10+11 Cooling (command) 12+13 Heating(command)	(factory occupied) (factory occupied) (factory occupied) (factory occupied)
11	Power supply 1 PE 2 Neutral 3 230V AC	(factory occupied) (factory occupied) (factory occupied)
12	D-Sub plug 37-poles The interface adapter SA988 is connected here.	

1.1. Connection – wiring guidelines

The following points must be ensured when the interfaces are wired:

- The interface adapter SA988 has to be connected to the protective earth (PE) on the unit at the designated point.
- There are only shielded interface cable are used.
- The power consumption respectively power switch should be suppressed as possible.

1.2. Interface adapter SA988 and pin assignment



RS-232	Pin	Signal	Meaning
	1		Tool-Temp Tool AG
	2	TxD	Data Transmit
	3	RxD	Data Receive
	4		
	5	GND	Masse
	6		
	7	CTS	Clear to Send
	8	RTS	Ready to Send
	9		

RS-485	Pin	Signal	Meaning
	1		
	2		
	3	A	Signal positive
	4		
	5	GND	Masse EIA-485
	6		
	7	B	Signal negative
	8		
	9		

CL-IN	Pin	Signal	Meaning
	1		
	2	S+	Send+
	3	S-	Send-
	4		
	5		
	6		
	7	E+	Receive+
	8	E-	Receive-
	9		

CL-OUT	Pin	Signal	Meaning
	1		
	2	S+	Send+
	3	E-	Receive-
	4		
	5		
	6		
	7		
	8		
	9		

CAN	Pin	Signal	Meaning toooo
	1		
	2	Low	CAN Signal low
	3	GND	CAN Ground
	4		

CAN	Pin	Signal	Meaning
	5	SHLD	Shielding the cable
	6		
	7	High	CAN Signal high
	8		
	9	24V	Looping

2. Overview programs of the controller

Once the „US-programs“ are set, the corresponding parameters are adjusted automatically on US-Gallons per minute and degree Fahrenheit.

Temperature control units without flow control			
Programme		New models	Old models
T 41	US T 41	TT-180, TT-181	TT-155, TT-156, TT-157 E, TT-162 E, TT-162H
T 42	US T 42	TT-170 L, TT-100 K-E, TT-100 KB-E	TT-162 E/PHE, TT-162 H/PHE, TT-162 E/A, TT-162 H/A, TT-154 E, TT-113 K, TT-103 K FeKo
T 43	US T 43		TT-130, TT-131, TT-132, TT-133, TT-134, TT-139
T 44	US T 44		TT-220, TT-230, TT-240, TT-245
T 45	US T 45		TT-260, TT-270, TT-280, TT-280/2
T 46	US T 46		TT-360, TT-370, TT-380, TT-380/2, TT-380 / 48 kW
T 47	US T 47		TT-300, TT-301, TT-302, TT-303, TT-304, TT-305, TT-500, TT-700

Temperature control units with flow control			
Programme		New models	Old models
T 72	US T 72	TT-DW160 9kW	
T 73	US T 73	TT-1358	
T 74	US T 74	TT-1398	TT-148
T 75	US T 75	TT-108 E / 6 - 18 kW / Pt-100	
T 76	US T 76	TT-108 K / 18 - 45 kW / Pt-100	
T 77	US T 77	TT-1000	
T 78	US T 78	TT-137 B/BP, TT-138 B/BP	
T 79	US T 79	TT-188, TT-168 E special unit 1,5 – 35 l/min	
T 80	US T 80	TT-188, TT-168 E, TT-168 H	
T 81	US T 81	TT-168 E/A, TT-168 H/A, TT-168 E/PHE, TT-168 H/PHE, TT-168 E/A/PHE, TT-168 H/A/PHE	
T 82	US T 82	TT-118 K, TT-1038 K, TT-108 K FeKo	
T 83	US T 83	TT-1548 E	
T 84	US T 84	TT-137 N-B, TT-138 N-B, TT-142 N-B, TT-142 B/BP	TT-143
T 85	US T 85	TT-288, TT-288/2	
T 86	US T 86	TT-1368	
T 87	US T 87	TT-388, TT-388/2, TT-390, TT-390/2	
T 88	US T 88	TT-388 / 48 kW, TT-608 Z	TT-380 / 48 kW with flow control

T 89	US T 89	TT-508 X, TT-510 X	TT-500 with flow control
T 90	US T 90	TT-708 Y	TT-700 with flow control
T 91	US T 91	TT-248	
T 92	US T 92	TT-407 Z, TT-409 Z	TT-408
T 93	US T 93	TT-410 X	
T 94	US T 94	TT-30/160	

Heating- and cooling units			
Programme		New models	Old models
W 09	US W 09	TT-13'502 10 - 90°C	
W 10	US W 10	TT-13'502 10 - 40°C	

Water chillers without flow control			
Programme		New models	Old models
W 11	US W 11	TT-29'000, TT-54'000, TT-54'000 WK, TT-54'000 OT, TT-108'000, TT-108'000 WK, TT-108'000 OT, TT-216'000, TT-216'000 WK, TT-216'000 OT, TT-14'000 E/LC	TT-4'500, TT-5'000, TT-9'500, TT-11'000, TT-11'000 WK, TT-12'000, TT-12'000 WK, TT-14'000, TT-14'000 WK, TT-20'000, TT-23'000, TT-23'000 WK, TT-25'000, TT-28'000, TT-28'000 WK, TT-29'000 WK, TT-40'000, TT-41'000, TT-57'000, TT-57'000 WK, TT-70'000, TT-80'000, TT-80'000 WK, TT-95'000, TT-95'000 WK, TT-110'000, TT-110'000 WK, TT-160'000, TT-160'000 WK
W 12	US W 12	TT-5'000 H, TT-14'000 H, TT-28'000 H, TT-5'000 E/LC	TT-4'500 H, TT-9'500 H, TT-11'000 H, TT-12'000 H, TT-14'000 H, TT-20'000 H, TT-23'000 H, TT-25'000 H

Water chillers with flow control			
Programme		New models	Old models
W 13	US W 13	TT-5'500 E, TT-14'500 H, TT-14'500 H/WK	
W 14	US W 14	TT-28'500, TT-28'500 WK, TT-28'500 OT, TT-29'500 WK, TT-54'500, TT-54'500 WK, TT-54'500 OT, TT-58'500 WK	

For all units with a special programming			
Programme		New models	Old models
T 100		Special programming	

3. Selection of the controller programme

By starting the controller, the selected programme (T80) is shown.
For an optimised controller operation each temperature control unit or water chiller requires a different programming of the parameters.



Start the unit, on the display follows...

Controller programme T72



Press button twice



With the arrow buttons choose the required programme
(see overview controller programmes)



Press button once to save



4. Settings

By starting the controller, the selected programme is shown.
After this the display shows the controller version (909) / controller hardware (E) / interface hardware (B), the interface (CL), the communication protocol (Arburg) and the address of the unit (1).
If no interface is set, "OFF/OFF" is displayed.



5. Navigation in the controller

Enter into the controller and navigate to the different parameter:

- To enter into the program of the controller, the programme button has to be pressed until the menu appears.
- In the main menu, choose the submenu „3. Parameter“ and press the programme button again.
- To move from parameter to parameter, press the two arrow buttons (confirm again with the programme button).



Setting the parameter value:

With the two arrow buttons the value of the parameters can be adjusted.



Save the parameter setting:

- To save the parameter settings and get back to the main menu, press the flow button.
- To get back to the control function, choose the submenu "1. Controller" in the main menu.



For all units with special programming T100:

If a parameter will be changed the controller shows T100. Controllers with a special programming have a written the parameters on a label on the controller and in the manual of the model.

**CAUTION**

Programming the controller only when the interface cable is unplugged.

6. Parameter – Overview

6.1. General

	Function	Factory adjusted	User	Agent	TOOL-TEMP	Description
P100	Language	0: English 1: German 2: French 3: Italian 4: Spanish				Here the desired language can be selected.
P101	Temperature unit	1: °C 2: °F				Temperature-unit for the indication of actual/set value as well as temperature relevant parameters. (Internally the temperature is always stored in °C)
P102	Flow unit	0: Flow OFF 1: Impulse (Hz) 2: Litre/min 3: US gallons/min 4: Imperial gallons/min				Indication of flow unit 1 US Gallone = 3.785 litres 1 Imperial Gallone = 4.546 litres
P110	Setting range FROM	Setting depends on each unit model (-50.0...399.0°C) (-58.0...750.2°F)				This parameter limits the lowest temperature which can be set.
P120	Setting range TO	Setting depends on each unit model (-49.9...400.0°C) (-57.8...752.0°F)				This parameter limits the highest temperature which can be set.
P150	Power measurement-coefficient	0.0 switched off 0.6 oil 1.0 water (0.0...10.0)				Power calculation: $P=k * (T_{x2}-T_{x3}) * Q$ P: Performance in kcal/h k: Coefficient of performance T _x : Sensor temperature Q: Flow rate in l/h
P151	Power measurement unit	0: switched off 1: W 2: kW 3: kcal/h				Unit of the power measurement
P160	Indication contrast	62 (45...80)				Setting of the display contrast
P170	Control parameter	0.5 (0.0...5.0)				Factory parameter

6.2. Inputs

	Function	Factory adjusted	User	Agent	TOOL-TEMP	Description
P200	Temperature sensor	Setting depends on each unit model FeKo Type J NiCr Type K Pt 100 2-wire				Selection of temperature sensor, applies for all 3 temperature inputs
P201	Temperaturabgleich bei Pt 100	0.7°C / 33.3°F (0.0...130.0°C) (0.0...234.0°F)				The resistance of the line can be compensated for Pt 100 on very long sensor cables. A comparative measurement is necessary for this purpose. Example: measured temperature: 100°C, temperature displayed: 108°C. -> 8°C set (difference)
P210	Analogue input	Voltage 0-10 V Current 0-20mA Current 4-20mA				Analog input of signal threshold. 0-10 V (Schaltschwelle <0.1V) 0-20 mA (Schaltschwelle <0.5mA) 4-20 mA (Schaltschwelle <0.1mA)
P212	Temperature of 0V at AIN	0°C / 32°F (-50.0...399.9°C) (-58.0...751.8°F)				Lower scaling point of voltage analog input 0V corresponds 0°C
P213	Temperature of 10V at AIN	400.0°C / 752.0°F (-49.9...400.0°C) (-57.8...752.0°F)				Upper scaling point of voltage analog input 10V corresponds 400°C
P214	Temperature of 0/4mA at AIN	0°C / 32°F (-50.0...399.9°C) (-58.0...751.8°F)				Lower scaling point of voltage analog input 4mA corresponds 0°C
P215	Temperature of 20mA at AIN	400.0°C / 752.0°F (-49.9...400.0°C) (-57.8...752.0°F)				Upper scaling point of voltage analog input 20mA corresponds 400°C

6.3. Controller

	Function	Factory adjusted	User	Agent	TOOL-TEMP	Description
P301	Sensor-Nr. Actual value of sensor	Setting depends on each unit model (1...3)				Indicates which sensor input is used for the controlling.
P302	Relation between cooling- and heating capacity	0 (1...50)				Adjustment of cooling capacity 0: 2-point cooling (standard) 1: Cooling capacity = Heating capacity 50: Cooling capacity > Heating capacity
P310	P-band heating, control parameter	Setting depends on each unit model (1.0...100.0°C) (1.8...180.0°F)				Within the proportional band is controlled PID-algorithm.
P320	Amplification factor I-proportion (K_I), control parameter	Setting depends on each unit model (0...100%)				Integration constant of the PID-control Controls the sensitivity/reactivity of the controller
P330	Differential portion heating and cooling, control parameter	Setting depends on each unit model (0...100%)				Differential proportion of the PID-control Controls the maximum regular rate of the controller
P340	Integration speed-limitingband, control parameter	Setting depends on each unit model (0.0...5.0°C) (0.0...9.0°F)				Prevents an overshoot of the temperature
P350	Delta-W – cooling	Setting depends on each unit model (-9.9...9.9°C) (-17.8...17.8°F)				Starting point of cooling If the setpoint exceeded this value the cooling system starts
P351	Hysteresis cooling	Setting depends on each unit model (0.2...25.0°C) (0.4...45.0°F)				Difference between activation and deactivation point of cooling. Temperature control units and Water Chillers adjust according to the controller setting table.
P360	Cycle time, control parameter	15s (6...255s)				Controller time base of PM-output Duration of the analysis of the control system to the readjustment of the correcting condition
P361	Minimal switching time heating, control parameter	2s (1...9s)				Minimal switching time for heating relay.
P362	Minimal switching time cooling, control parameter	1s (0.5...9s)				Minimal switching time for cooling relay.

6.4. Flow control

	Function	Factory adjusted		User	Agent	TOOL-TEMP	Description
P400	Flow measurement function	0: Off 1: Automatic 2: Manual					If the automatic flow measurement is activated, the measured flow is stored as a reference after an initial period of 15 s (after start of the unit) and monitoring is enabled. The green LED lights up.
P401	Flow measurement calibrating table	0 = Manual 1 = Small units 1 2 = Medium units 3 = Large units 4 = Reserved 5 = Small units 2 6 = Reserved					Selection of the calibration table for flow measurement
P410	Alarmschwelle Durchfluss	8.0 l /min (0.1...999.9 l/min)					(P400) set to manual Alarm is triggered when the set value is exceeded.
P420	lower alarm threshold (P431)	30%					Applies only to automatic mode (P400 = 1) and calculates the alarm point
P421	top alarm threshold (P431)	10%					Applies only to automatic mode (P400 = 1) and calculates the alarm point
P431	Flow measurement Measuring point 1	x Hz	y l/min				Relevant calibration table for flow measurement by P401
P432	Flow measurement Measuring point 2	x Hz	y l/min				Relevant calibration table for flow measurement by P401
P433	Flow measurement Measuring point 3	x Hz	y l/min				Relevant calibration table for flow measurement by P401
P434	Flow measurement Measuring point 4	x Hz	y l/min				Relevant calibration table for flow measurement by P401
P435	Flow measurement Measuring point 5	x Hz	y l/min				Relevant calibration table for flow measurement by P401

6.5. Outputs

	Function	Factory adjusted	User	Agent	TOOL-TEMP	Description
P510	Output function	0: P511,P512 1: 10V=100% 2: 5V=0% 3: Flow				Voltage-analog output 0 : Actual value P511...P512 -> 0...10V 1 : Size 0...100% -> 0...10V 2 : Size -100...0...100% -> 0..5...10V 3 : Flow 0...P435 -> 0...10V
P511	Temperature at 0 V AOUT	0.0°C / 32.0°F (-50.0...399.9°C) (-58.0...751.8°F)				Lower scaling point of voltage analog input 0V corresponds 0°C
P512	Temperature at 10 V AOUT	400.0°C / 752°F (-49.9...400.0°C) (-57.8...752.0°F)				Upper scaling point of voltage analog input 10V corresponds 400°C
P520	Relay 1 function	1: Maximal temperature 2: Limit value 1 3: Limit value 2 (not integrated) 4: Limit 1 or Limit 2 5: Difference to mould / from mould 6: Drain 7: Unit on/off 8: Flow measurement alarm				The relay 1 can be programmed, that is switches on with different signals. Standard: Unit on/off
P530	Relay 2 function	1: Maximal temperature 2: Limit value 1 3: Limit value 2 (not integrated) 4: Limit 1 or Limit 2 5: Difference to mould / from mould 6: Drain 7: Unit on/off 8: Flow measurement alarm				The relay 2 can be programmed, that is switches on with different signals. Standard: Limit 1 or Limit 2
P560	Relay 5 function	1: Maximal temperature 2: Limit value 1 3: Limit value 2 (not integrated) 4: Limit 1 or Limit 2 5: Difference to mould / from mould 6: Drain 7: Unit on/off 8: Flow measurement alarm				The relay 5 can be programmed, that is switches on with different signals. Standard: Flow measurement alarm

The relay 3 (cooling) and relay 4 (heating) cannot be programmed.

6.6. Limit values

	Function	Factory adjusted	TOOL-TEMP			Description
			User	Agent	TOOL-TEMP	
P600	Maximal temperature	Setting depends on each unit model (0.0...400.0°C) (32.0...752.0°F)				If the maximum temperature is exceeded, heating and cooling are inactive and the maximum value LED on the controller lights.
P602	Safety thermostat T2	0°C / 0°F (0...50.0°C) (0...90.0°F)				0 = T2 inactive see below for detailed explanation
P610	Starting interlock	1: On 0: Off				The activation of the temperature deviation occurs after initial power and first reaching the target temperature.
P611	Temperature deviation control (deviation between the desired and actual temperature)	5.0°C / 9.0°F (0...20.0°C) (0...36.0°F)				The temperature deviation control determines the maximum deviation from the nominal value, which is still tolerated. If the actual temperature outside the set value window, the alarm sounds and the limit LED lights. If the restart interlock (P610) is activated, the temperature deviation control is active only when it reaches the set temperature. The starting lockout starts when the set point is changed.
P630	Safety temperature	50.0°C / 122.0°C (-50.0...400.0°C) (-58.0...752.0°F)				Operation with interface: When the corresponding command is received through the interface, this temperature will be attained.
P631	Trail temperature	70.0°C / 158.0°F (-50.0...400.0°C) (-58.0...752.0°F)				Operation with interface: When the corresponding command is received through the interface, this temperature will be attained.
P640	Drain time	30s (5...120s)				Time of draining after reaching the target temperature.

Maximum temperature P600 (Tmax): As soon as the evaluated temperature of the temperature sensor (T1) is higher as the parametrising value, the cooling and heating relay are obligatory open. The normal control operation starts if the temperature is again below this temperature.

Safety thermostat P602:

The set value in this parameter 602 defines the maximum allowable temperature limit of the additional measurement point (temperature sensor 2) to the set value. The setting of this parameter is 0...50.0°C (resp. 0...90°F). The temperature sensor 2 must be connected to the desired control point for this function.

Example 1: T1 measures the temperature of the product in a double-walled vessel, T2 measures the temperature in the unit, P602 is set to 3°C -> T2 is more than 3°C above the set temperature and interrupts the heating command.

Example 2: T1 measures the temperature in the unit, T2 measures the temperature outside the unit on a mould, P602 is set to 3°C-> T2 is more than 3°C above the set temperature and interrupts the heating command.

If this safety thermostat is active the error message "safety thermostat" is shown on the display.

6.7. Ramp controller

Temperature curves can be traversed in function time with this controller. The curves can be programmed with 10 points and 8 curves can be stored.

The flow control and temperature deviation control are inactive in this control method.

Enter into the controller for adjusting the ramp control:

- To enter into the program of the controller, the program button has to be pressed until the menu appears.
- In the main menu, choose the submenu „2. Ramp controller” and press the program button again.
- Navigate between the menu with the arrow buttons

Start: Start the ramp control (start with the selected curve)

With the flow button the controller is interrupted and switches back to the ramp controller menu

Curve: Select the ramp control curve 1...8

Navigate with the arrow keys to the desired curve

Confirm with the flow button and use the arrow buttons to switch back and "start" the ramp controller

Change: Edit the selected curve

Use the arrow buttons to select the curve points 1...10 and edit them. Set-curve can be determined by: **setpoint, gradient** or **time** (can only be changed when gradient =0)

Selected with the program button

Edit value with arrow keys

Confirm with the flow button and use the arrow buttons to switch back and „start“ the ramp controller



Parameters: Selection ramp control mode

Using the modes „Cycle“ or „Timehold“ with the arrow buttons:

Cycle: Cyclic passing through the curve; repetitive (Cycle: On)
If the curve only runs through once (Cycle: Off) the follow temperature regulates at P631.

Timehold: If the temperature must be maintained the timehold is relevant. The temperature holding time would be counted after the setpoint value is reached. The parameter P791 defines the allowable timeout for reached the setpoint. The light-dark change of the display visualized the “non-compliance”.

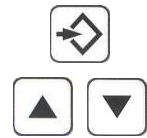

The desired modes „On“ / „Off“ can be selected with the program button

Pressing the flow button to switch back to the ramp control menu

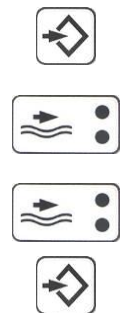

Leaving the ramp controller:

- To save the parameter settings and get back to the main menu, press the flow button.
- To get back to the control function, choose the submenu “1. Controller” in the main menu.

Examples ramp controller

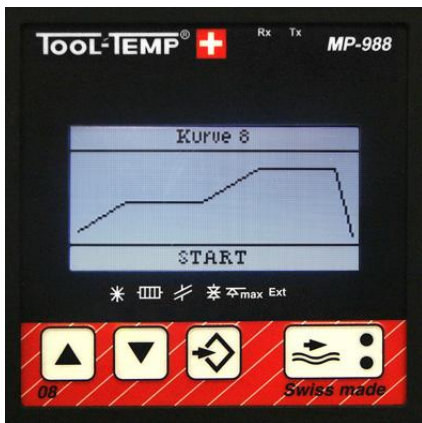

Curve 8 is set and can be started by the program button.

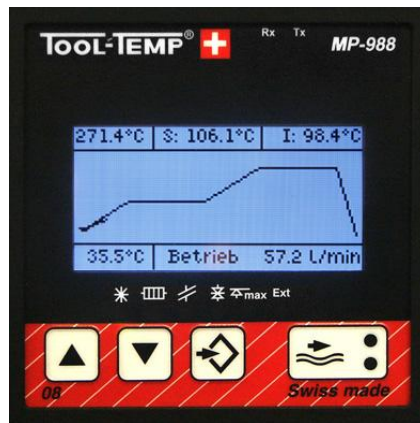

The actual value are „plotted“. The temperature limit (35.5°C; line below the curve), the operating mode and the actual flow displayed in the bottom line. The top line shows the temperature limit (271.4; line above the curve), the setpoint and actual value.

The following parameters are applied only for the ramp control.

	Function	Factory adjusted	User	Agent	TOOL-TEMP	Description
P722	Relation heating- and cooling capacity	Setting depends on each unit model (0...50)				0: PID heating control, 2 points cooling 1...50 PID heating/cooling control
P723	P-Band heating, control parameter	Setting depends on each unit model (1.0...100.0°C) (1.8...180°C)				Within the proportional band is controlled PID-algorithm.
P724	Amplification factor I-quantity (K_I), control parameter	Setting depends on each unit model (1...100%)				Integration constant of the PID-control Controls the sensitivity/reactivity of the controller
P725	Differential percentage heating and cooling, control parameter	Setting depends on each unit model (0...100%)				Differential proportion of the PID-control Controls the maximum regular rate of the controller
P726	Integration limit band, control parameter	Setting depends on each unit model (0.0...5.0°C) (0.0...9.0°F)				Prevents an overshoot of the temperature
P727	Delta-W – cooling	Setting depends on each unit model (-9.9...9.9°C) (-17.8...17.8°F)				Starting point of cooling If the setpoint exceeded this value the cooling system starts
P728	Hysteresis cooling	Setting depends on each unit model (0.2...25.0°C) (0.4...45.0°F)				Difference between activation and deactivation point of cooling. Temperature control units and Water Chillers adjust according to the controller setting table.
P730	Cycle time, control parameter	15s (6...255s)				Controller time base of PM-output Duration of the analysis of the control system to the readjustment of the correcting condition
P731	Minimum switching time heating, control parameter	2s (1...9s)				Minimum switching time for heating relay. If P722 is 0, then also relevant for cooling relay.
P732	Minimum switching time cooling, control parameter	1s (0.2...9s)				Minimum switching time for cooling relay. Only active if P722 greater than 0.
P791	Maximal delay of reaching the set value	10 min (1...120 min)				If the set value is not reached within the adjusted time period, there is a break-off.

6.8. Communication

	Function	Factory adjusted	User	Agent	TOOL-TEMP	Description
P800	Physical interface	0: Switched off 1: RS232 2: RS485 3: Current Loop 4: CAN				The physical interface is defined here.
P801	ComProtocol Communication- protocol	0: Switched off 1: Arburg 2: Engel 3: Krauss – Maffei 4: Bühler 1 5: Italpress 6: Dr. Boy 7: Battenfeld 8: Demag (RS232, CL) 9: Ferrom. – Millacron 10: Frech 11: Stork 12: Müller weing. 13: Euromap 17 14: Billion 15: Fanuc 16: Husky 17: Demag (CAN) 18: Euromap 66 (CAN) 19: Bühler 2				The interface protocol is defined here.
P802	ComAdress Address of the unit	1 (1...253)				For multiple units, each number has to be incremented.
P830	Reserve - Bit Standard interface	1 (0...1)				Transmission speed of the CAN, respectively the Profibus interface
P840	CAN - Baudrate	<i>Nr.</i> <i>CAN</i> 0: 125 kBit/s 1: 250 kBit/s 2: 500 kBit/s 3: 615 kBit/s 4: 625 kBit/s 5: 750 kBit/s 6: 1000 kBit/s				Transmission rate of CAN-interface.

7. Communication – Overview Interfaces

7.1. Interfaces (P800)

The temperature controller MP-988 offers a choice of physical interface types: RS-232, RS-485, Current Loop 20mA oder TTY oder CAN-bus.

7.2. Protocols (P801)

Several protocols of different machine manufacturers are supported. The choice of the protocol in the parameter menu does not only switch over the interface, it also selects the machine specific interface-parameters.

Manufacturer	Layer 0	Interface
Arburg	CL 20 mA half-duplex	4800 baud, 1 start, 8 daten, 1 stop, parity even
Engel	CL 20 mA half-duplex	4800 baud, 1 start, 8 daten, 1 stop, parity none
Demag	CL 20 mA half-duplex	4800 baud, 1 start, 8 daten, 1 stop, parity even
Krauss Maffei MC-4 (alt)	CL 20 mA half-duplex	4800 baud, 1 start, 8 daten, 1 stop, parity even
Krauss Maffei MC-5	CL 20 mA half-duplex	4800 baud, 1 start, 8 daten, 1 stop, parity even
Stork	CL 20 mA half-duplex	2400 baud, 1 start, 8 daten, 1 stop, parity even
Battenfeld - Uniloc B4	CL 20 mA half-duplex	4800 baud, 1 start, 8 daten, 1 stop, parity even

Demag	RS-232	4800 baud, 1 start, 8 daten, 1 stop, parity even
DrBoy	RS-232	4800 baud, 1 start, 8 daten, 1 stop, parity even
Engel (Rosendahl)	RS-232	4800 baud, 1 start, 8 daten, 1 stop, parity none
Ferromatik	RS-232	4800 baud, 1 start, 8 daten, 1 stop, parity even
Stork	RS-232	2400 baud, 1 start, 8 daten, 1 stop, parity even

Bühler 1	RS-485	9600 baud, 1 start, 8 daten, 1 stop, parity even
DrBoy	RS-485	4800 baud, 1 start, 8 daten, 1 stop, parity even
Engel	RS-485	4800 baud, 1 start, 8 daten, 1 stop, parity none
Frech	RS-485	9600 baud, 1 start, 8 daten, 1 stop, parity even
Italpresse	RS-485	9600 baud, 1 start, 8 daten, 1 stop, parity even
Müller Weingarten (alt)	RS-485	9600 baud, 1 start, 8 daten, 1 stop, parity even
Billion	RS-485	9600 baud, 1 start, 8 daten, 1 stop, parity even
Euromap 17	RS-485	9600 baud, 1 start, 8 daten, 1 stop, parity even
Fanuc	RS-485	9600 baud, 1 start, 8 daten, 1 stop, parity even
Husky	RS-485	9600 baud, 1 start, 8 daten, 1 stop, parity even

Demag	CAN-bus	615 kBit/s
Netstal Euromap 66	CAN-bus	250 kBit/s
Bühler 2	CAN-bus	250 kBit/s

NOTE

The serial operation with Current Loop from temperature control units to the injection moulding machine is only possible if all temperature control units are connected and switched on.

The communication is interrupted if individual units in the series (CL) are switched off.

8. Connection diagrams – communication connection

8.1. Interface RS-232 – connection diagram

At this interface each temperature control unit has to be connected to the injection moulding machine separately. On the temperature controller MP-988 are the parameter: P800, P801 adjust accordingly.

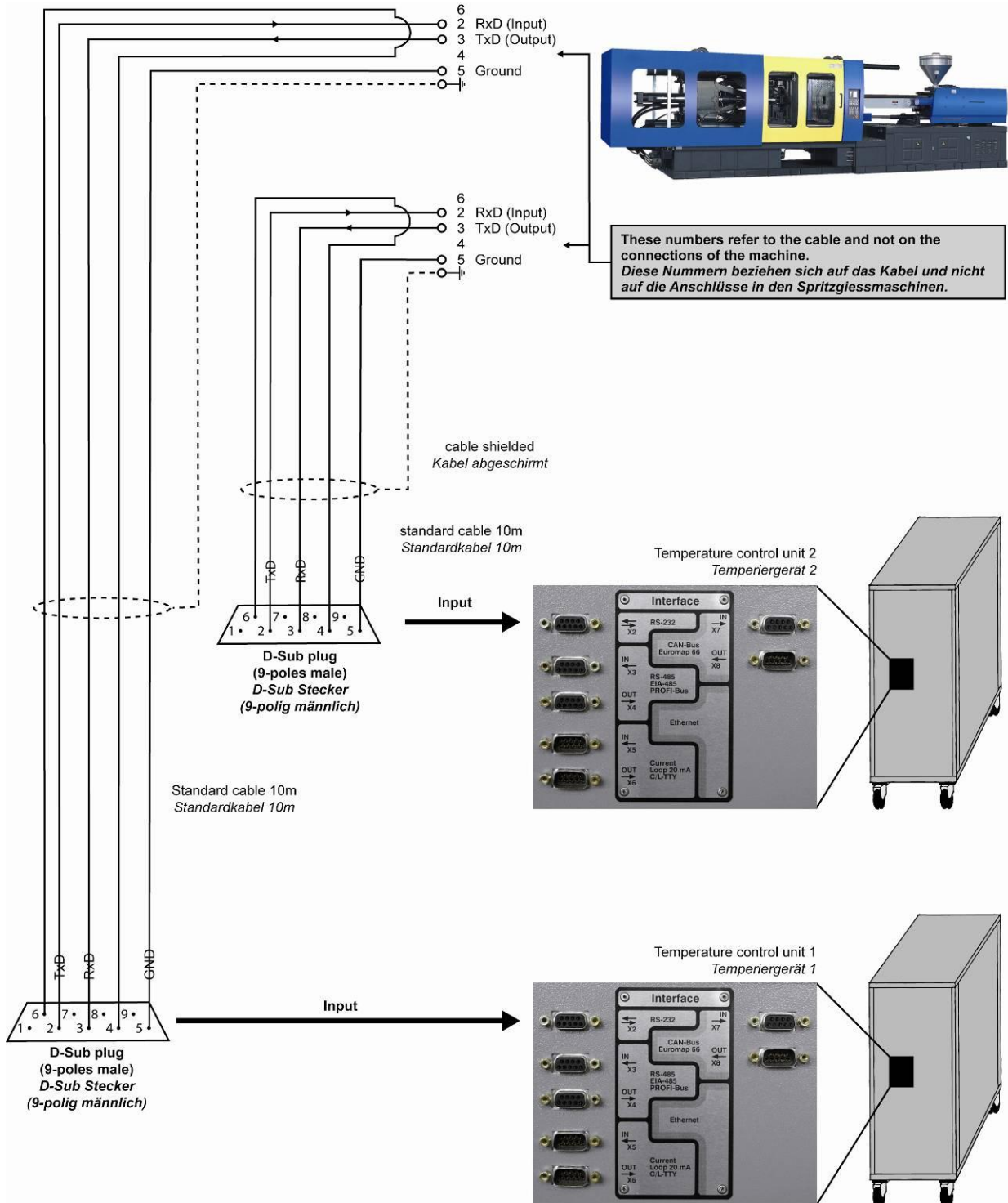

8.2. Interface Current Loop 20mA or TTY – connection diagram

The serial operation with Current Loop from temperature control units to the injection moulding machine is only possible if all temperature control units are connected and switched on. The communication is interrupted if individual units in the series (CL) are switched off.

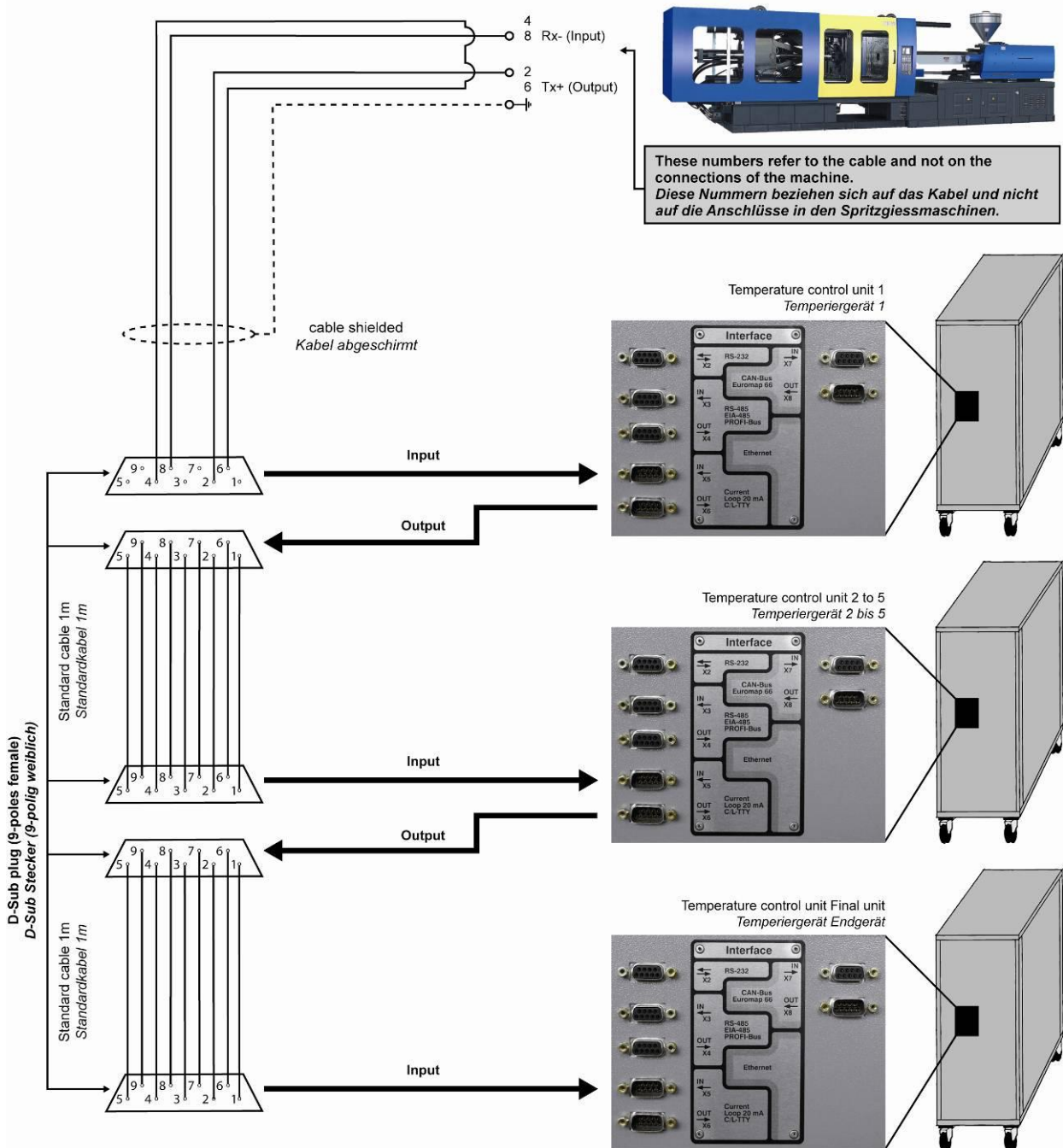

8.3. Interface CL or TTY – Configuration of the connection panel

The Current Loop or TTY interface has to be configured with the DIP-switches at the rear side of the connection panel.

Connection panel front side

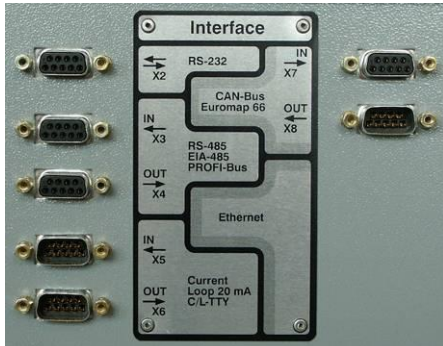

Rear side

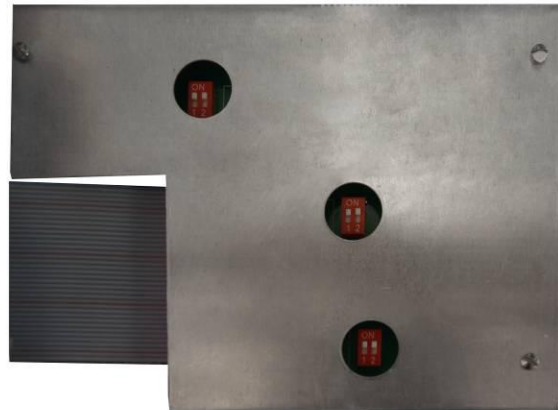

Configuration at the rear side of the panel at the corresponding quantity of temperature control units (TCU):

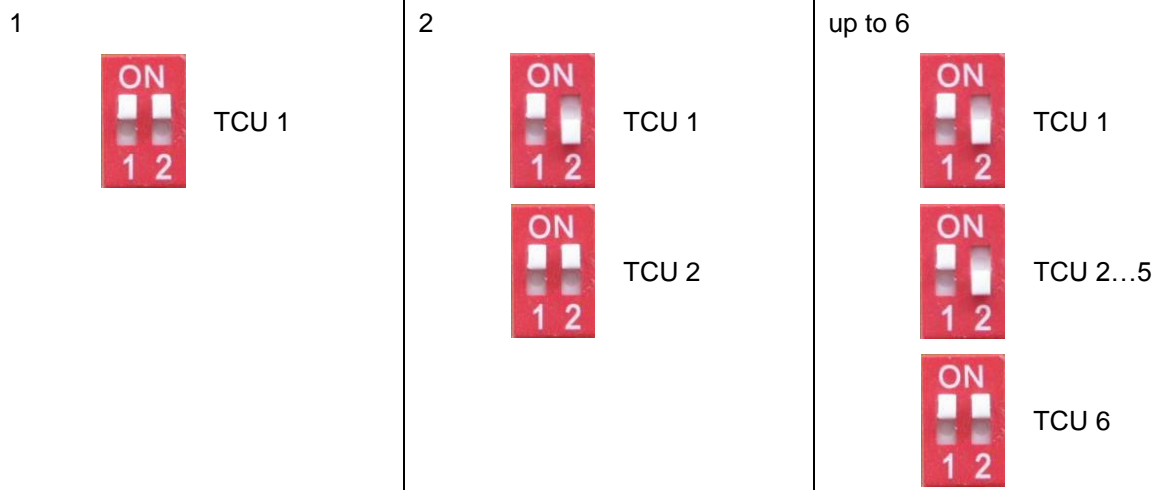

On the temperature controller MP-988 are the parameters: P800, P801 and P802 (address of the unit – has to be matched with the injection mould machine display) adjust accordingly.

NOTE	
	<p>P840 (CAN – baud rate) has not to be set, this is defined by P801.</p> <p>Programming the controller only when the interface cable is unplugged.</p>

8.4. Interface wire to Krauss Maffei-Injection moulding machine for CL 20mA

It needs a "special cable" with different connector types to connect the Krauss Maffei injection mould machine with the temperature control unit.

Cable side 1 TOOL-TEMP unit				Cable side 2 Krauss Maffei machine		
D-Sub 9-poles (female)				D-Sub 25-poles (male)		
PIN 2	Send	Tx+	Strand Nr.2, red	->	PIN 24	Strand red
PIN 8	Receive	Rx-	Strand Nr.8, gray	->	PIN 10	Strand gray
PIN 6	No function		Strand Nr.6, dark blue	->	PIN 4	Strand dark blue
PIN 4	No function		Strand Nr.4, yellow	->	PIN 6	Strand yellow
						Make a bridge

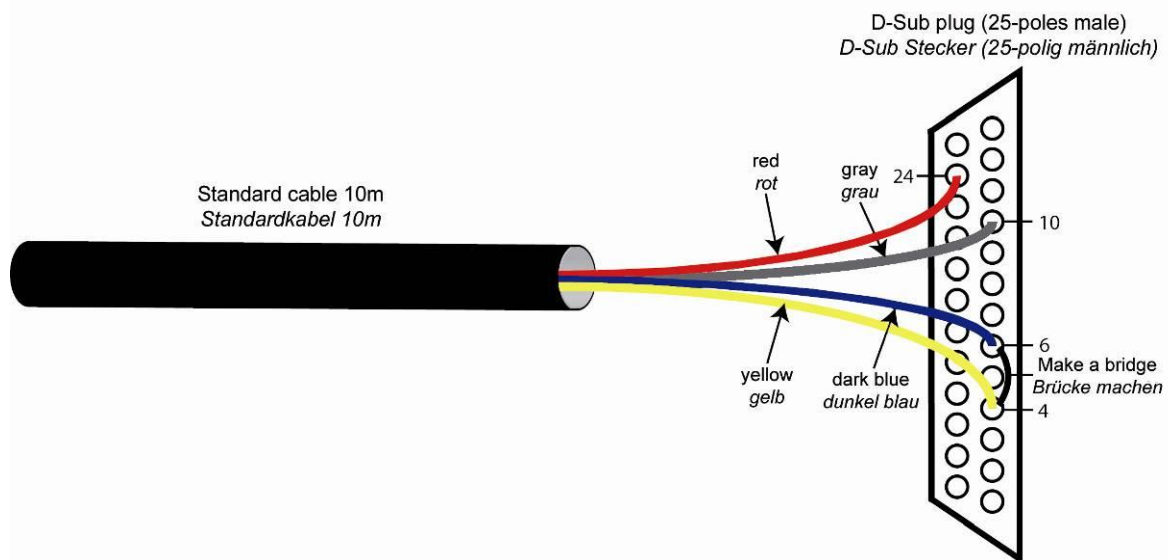

8.5. Interface RS-485– connection diagram

With this interface it is possible to connect up to 16 units in series.

4-wire

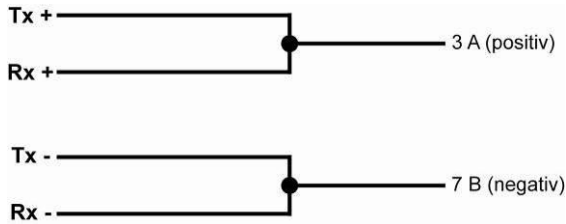

Connection diagram: Interface RS-485, 4-wire: Should the interface on the machine side be a 4-wire system, the connection can be made as shown on the left side.

The steering of the injection moulding machine might have to be changed from **full duplex** to **halb duplex**.

2-wire

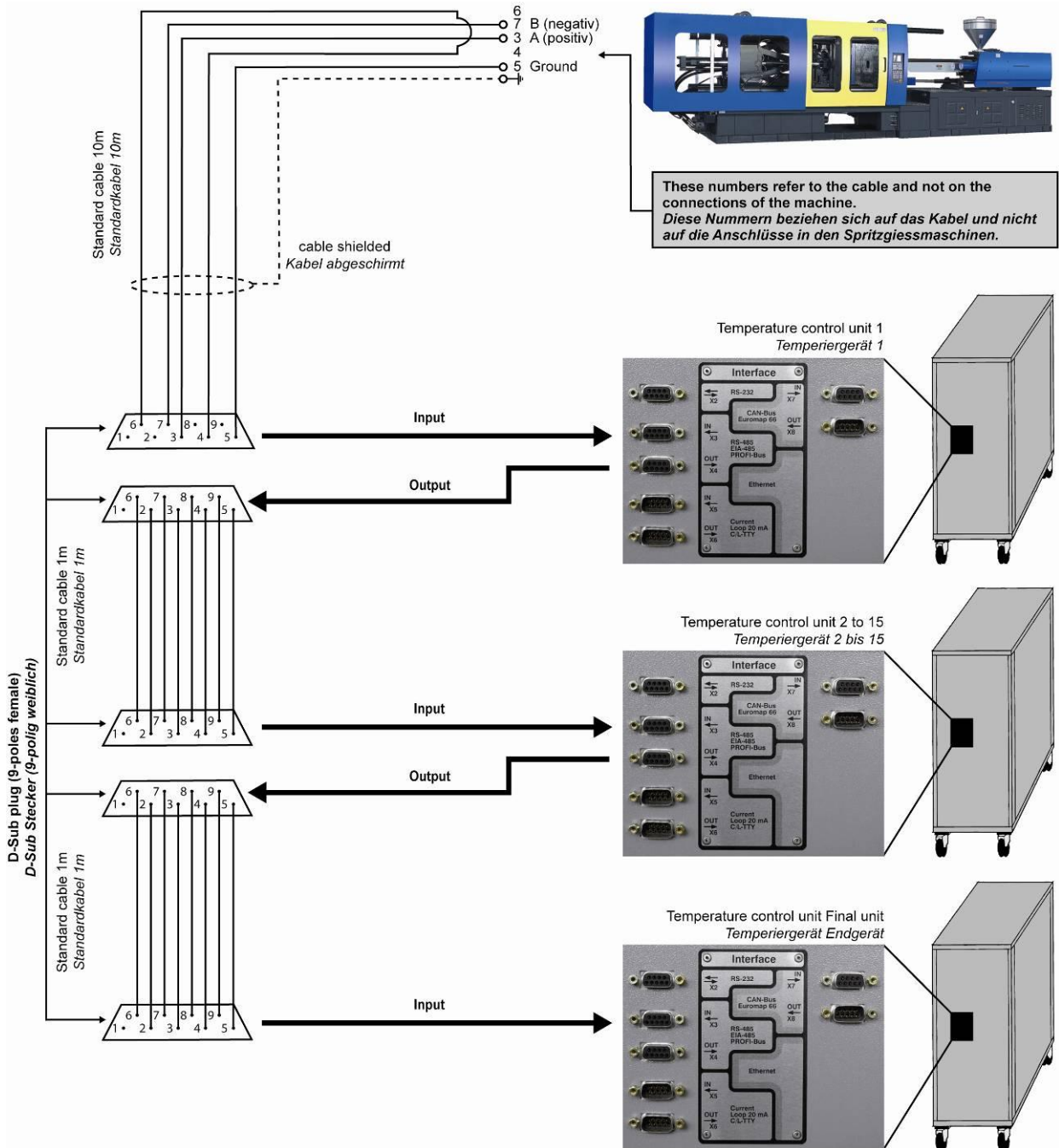

These numbers refer to the cable and not on the connections of the machine.
Diese Nummern beziehen sich auf das Kabel und nicht auf die Anschlüsse in den Spritzgiessmaschinen.

8.6. Interface RS-485 – Configuration of the connection panel

The interface RS-485 has to be configured with the DIP-switches at the rear side of the connection panel.

Connection panel front side

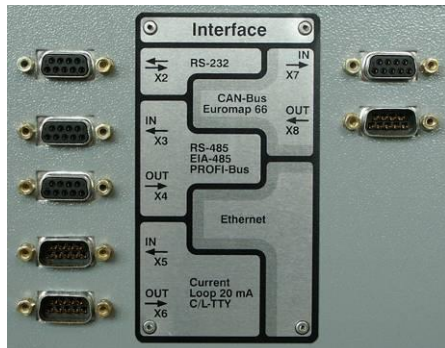

Rear side



Configuration at the rear side of the panel at the corresponding quantity of temperature control units (TCU):

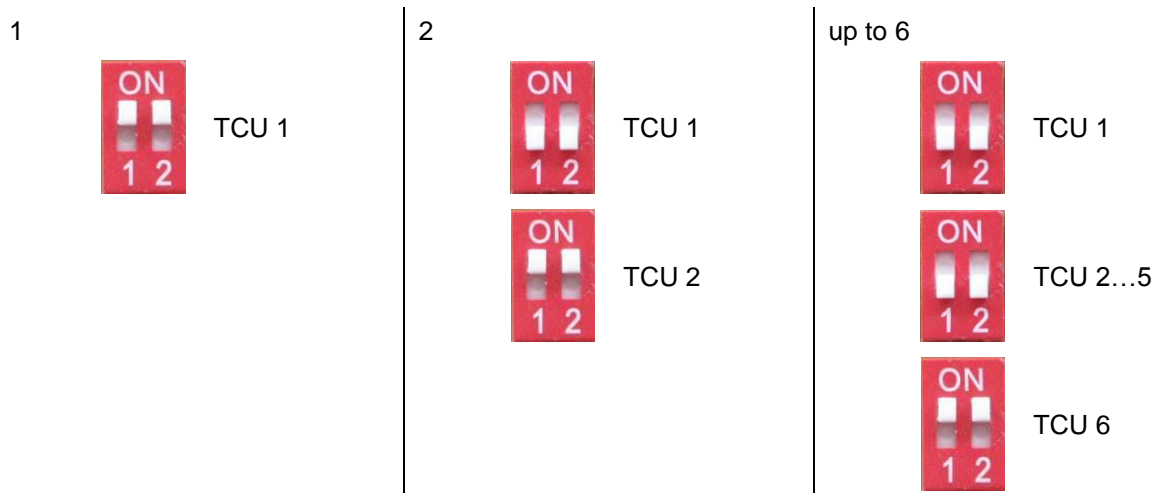

On the temperature controller MP-988 are the parameters: P800, P801 and P802 (address of the unit – has to be matched with the injection mould machine display) adjust accordingly.

NOTE	
	<p>P840 (CAN – baud rate) has not to be set, this is defined by P801.</p> <p>Programming the controller only when the interface cable is unplugged.</p> <p>No terminal resistor has to be installed! The terminal resistor is integrated in the DIP-switch.</p>

8.7. Interface CAN-bus – Connection diagram

With this interface it is possible to connect up to 10 units to one injection moulding machine. Only CAN-bus cables have to be used.

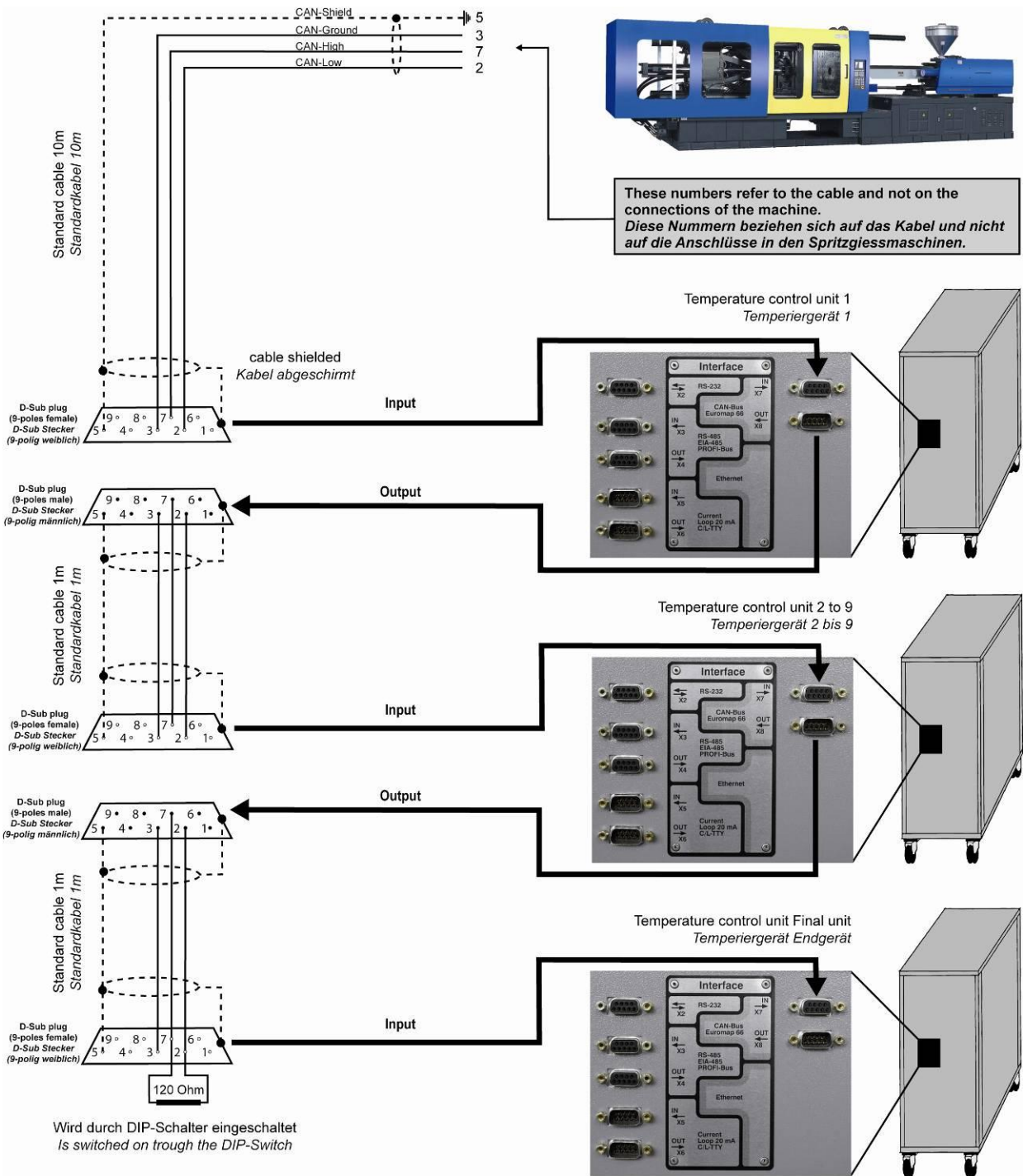

8.8. Interface CAN-bus – Configuration of the connection panel

The interface CAN-bus has to be configured with the DIP-switches at the rear side of the connection panel.

Connection panel front side

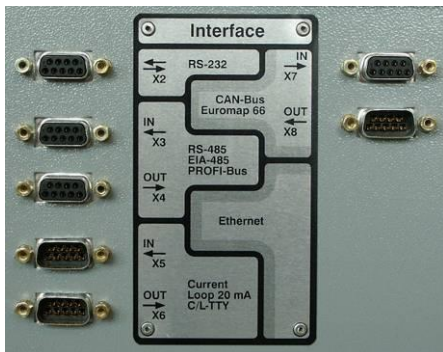

Rear side



Configuration at the rear side of the panel at the corresponding quantity of temperature control units (TCU):

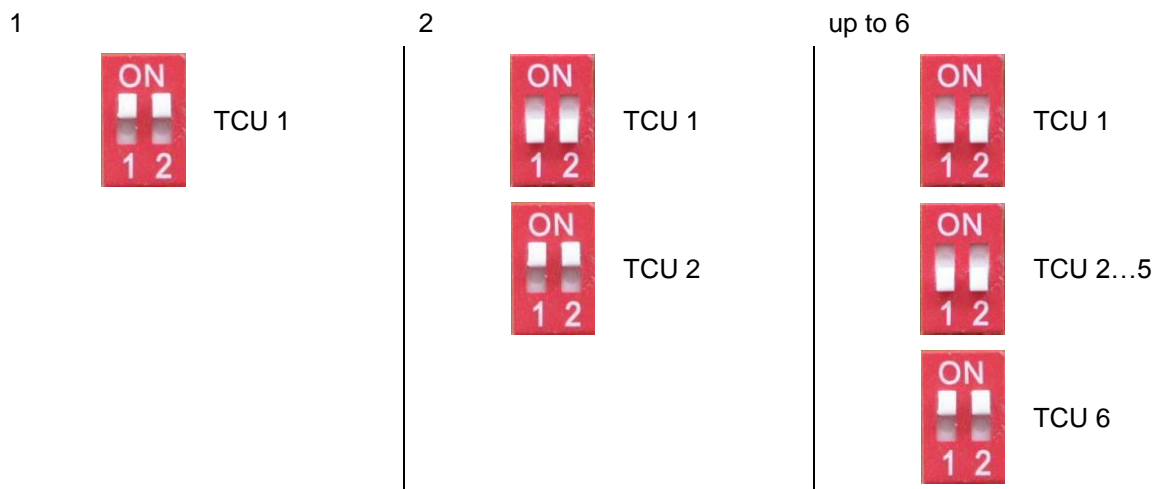

On the temperature controller MP-988 are the parameters: P800, P801 and P802 (address of the unit – has to be matched with the injection mould machine display) and P840 (CAN – baud rate; standard 615kBit/s) adjust accordingly.

CAUTION	
	<p>Programming the controller only when the interface cable is unplugged.</p> <p>If Netstal machine are used, the temperature control unit has to be connected before the injection mould machine has been put into operation. The temperature control unit should not be plugged in if the injection mould machine runs.</p>